

The background features a white marble texture overlaid with horizontal blue lines, characteristic of notebook paper. Scattered throughout are slices of grapefruit and orange, along with small sprigs of green herbs.

# Arabic Reader

Part 1

With Coloring

# ARABIC READER

ARABIC LANGUAGE LESSONS  
*for*  
GRADE ONE

بِسْمِ اللَّهِ الرَّحْمَنِ الرَّحِيمِ

In the Name of Allah, Most Gracious, Most Merciful

## Table of Contents

01 – The Arabic Alphabets	... 03
02 – The Book of Food	... 15
03 – The Book of Animals	... 35
04 – The Book of Shapes	... 49
05 – My Colouring Book - 1	... 57
05 – My Colouring Book - 2	... 79
05 – My Colouring Book - 3	... 99
07 – Teaching Instructions	... 119

# The Arabic Alphabets

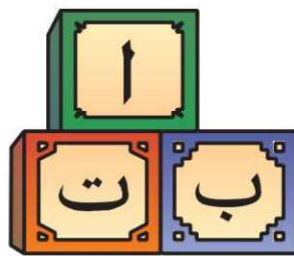

# Helping your child



The activities in this book should be enjoyed by your child and yourself.

Try to find a quiet place to work.



Always give your child lots of encouragement and praise.





أَب

Father

ا

ALIF

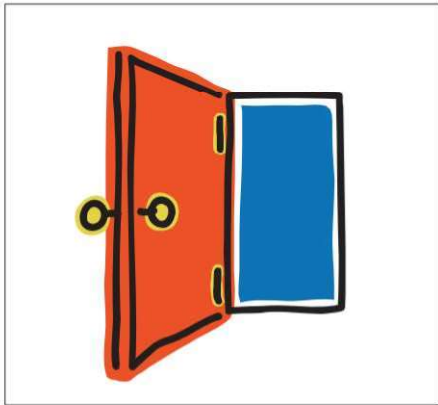

بَاب

Door

ب

BAA

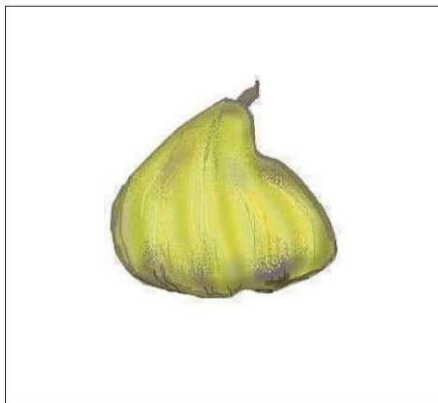

تَيْن

Fig

ت

TAA

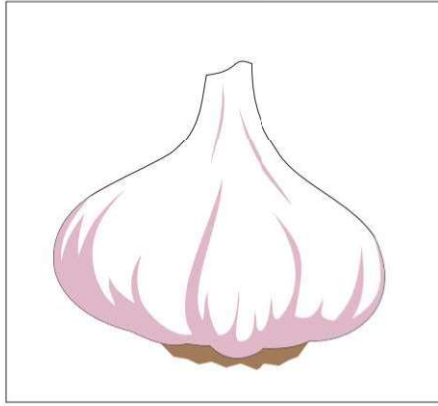

ثُومٌ

Garlic

ث

THAA

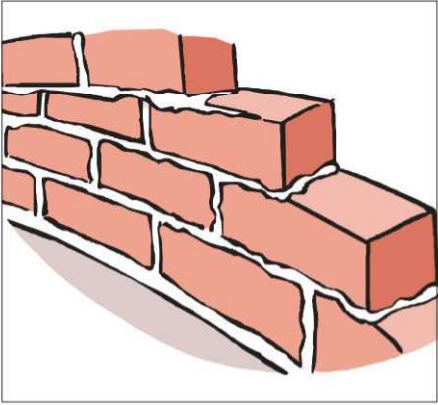

جِدَارٌ

Wall

ج

JEEM



حَلَالٌ

Halaal

ح

`HAA

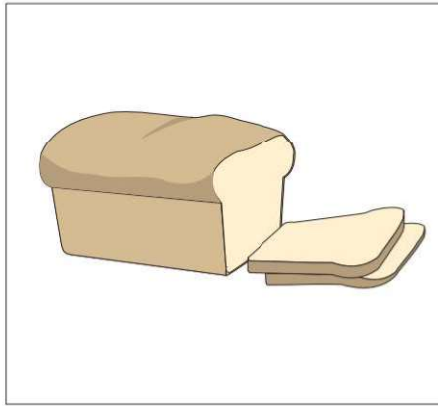

خُبْزٌ

Bread

خ

KHAA



دَارٌ

Home

د

DAAL



ذَهَبٌ

Gold

ذ

DHAAL



رَجُلٌ

Man



RAA



زَوْجٌ

Wife



ZAA

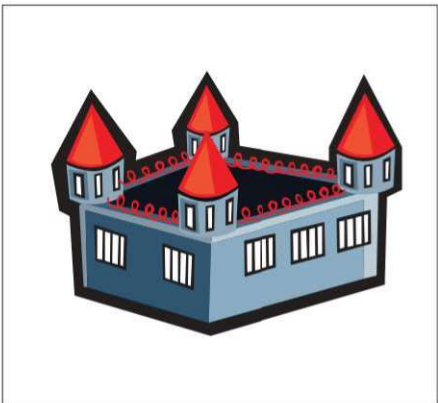

سِجْنٌ

Jail



SEEN



شِتَاءٌ

Winter

ش

SHEEN

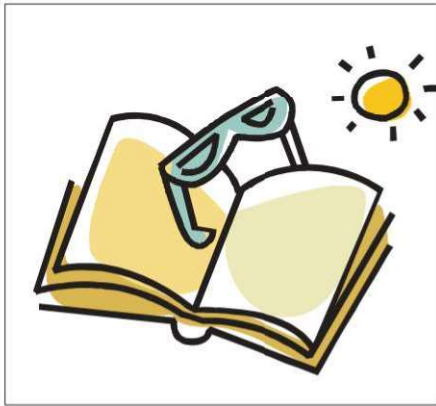

صَيْفٌ

Summer

ص

SAAD



ضَعْفٌ

Weakness

ض

DAAD

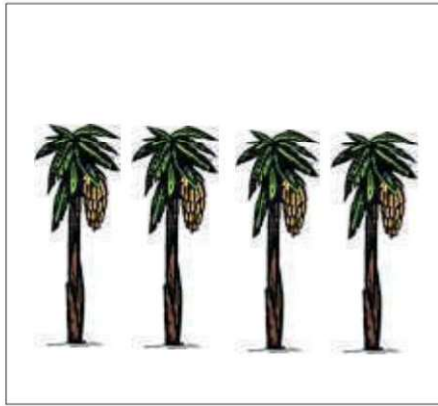

طَلْحُ

Banana  
trees

ط

TAA'

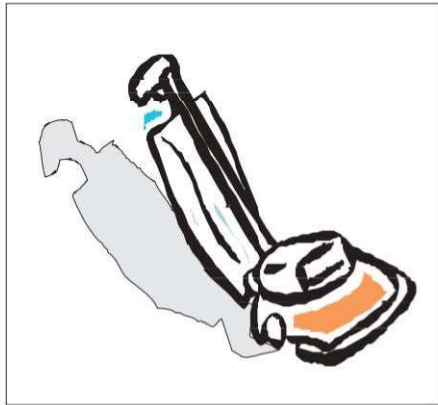

ظِلُّ

Shadow

ظ

ZAA'

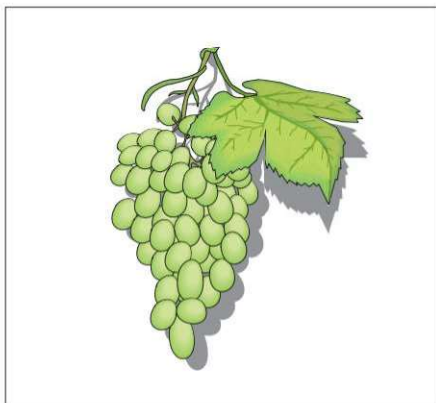

عِنَبٌ

Grapes

ع

'AYN



غَارٌ

Cave

غ

'GHAYN



فُلْكَ

Ship

ف

FAA



قَلَمٌ

Pen

ق

QAAF



كِتَابٌ

ك

Book

KAAF



لَبَنٌ

ل

Milk

LAAM



مَالٌ

م

Wealth

MEEM



نَوْمٌ

ن

Sleep

NOON

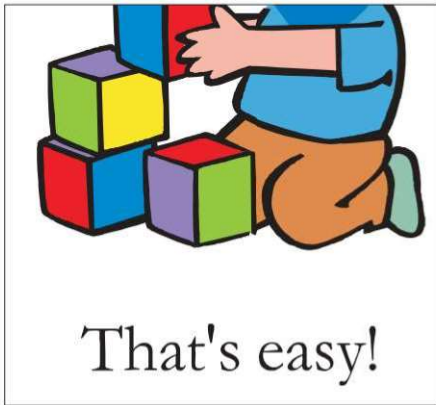

هَيِّنْ

ه

Easy

HAA



وَلَدٌ

و

Boy

WAAW

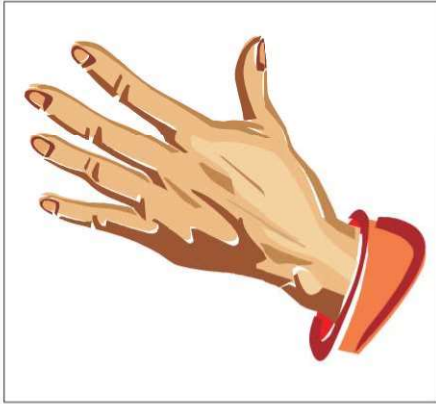

يَدٌ

Hand

ي

YAA

## The Arabic Alphabets

ا ب ت ث

ج ح خ د ذ ر ز

س ش ص ض ط ظ

ع غ ف ق ك

ل م ن ه و ي

# The Book of Food

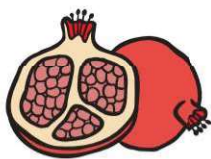
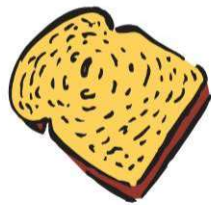

# Helping your child



The activities in this book should be enjoyed by your child and yourself.

Try to find a quiet place to work.



Always give your child lots of encouragement and praise.



1

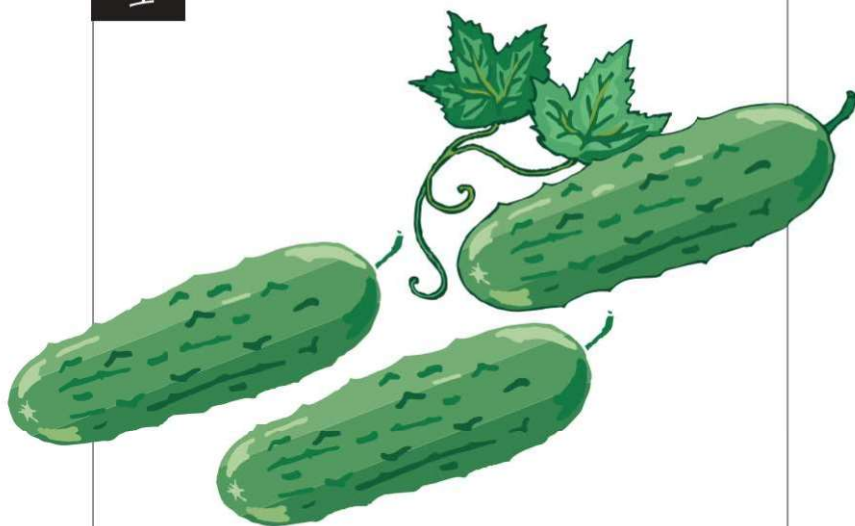

قُبَاب

Cucumbers

2



عَدَسٌ

Lentils

3



بَجَلٌ

Onions

٢٤

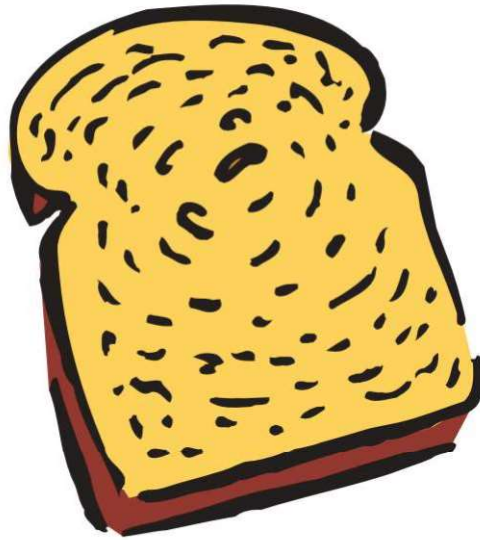

خُبْز

Bread

Exercise 1:

Draw a line to join the picture with the Arabic word.



خبز

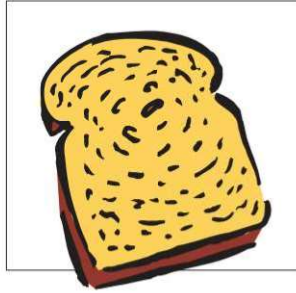

بصل

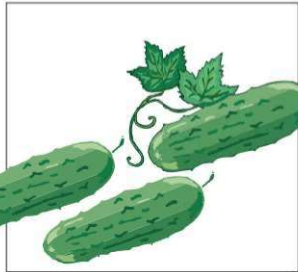

عدس

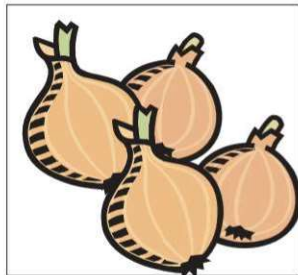

فتا

Exercise 2:

Do you know what letter is missing from the beginning of these words?

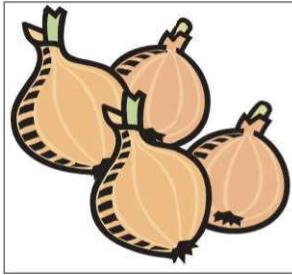

حَلَّ..



لَسَّ..

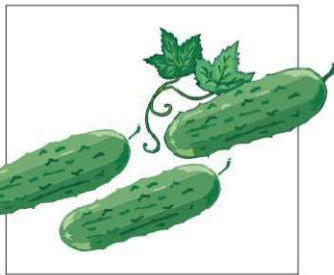

تَلَّ..

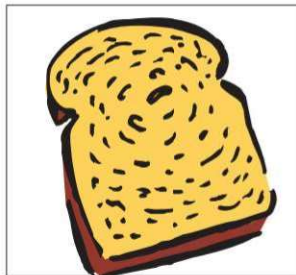

بَزَّ..

٥



عَسَلٌ

Honey

6

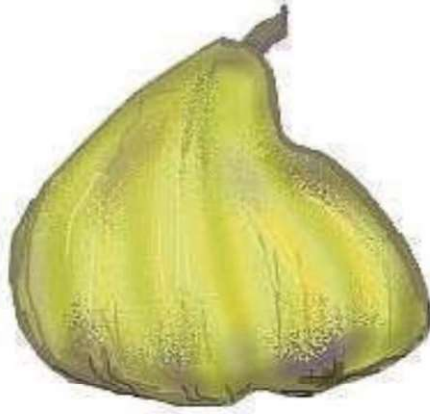

تَيْن

Fig

7



زَيْتُون

Olives

8

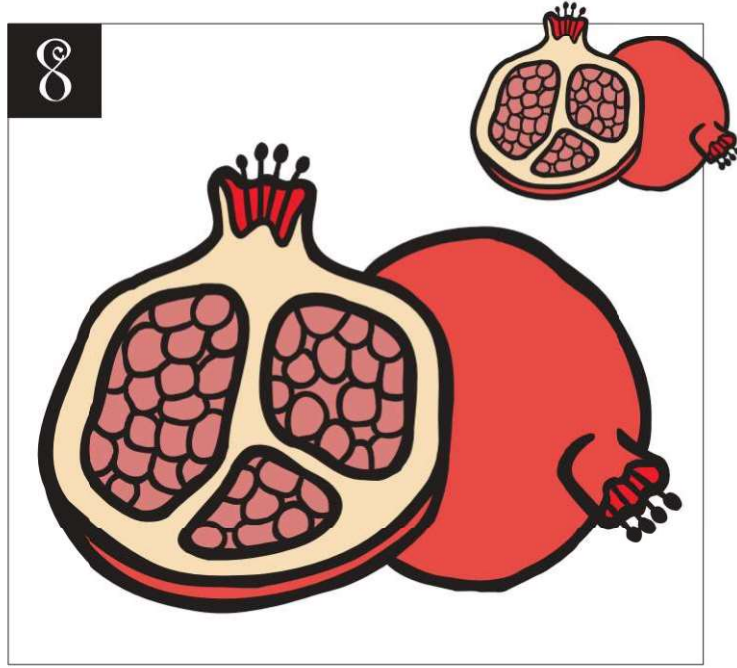

رُؤْمَانٌ

Pomegranates

Page 11

Exercise 3:

Draw a line to join the picture with the Arabic word.



تَيْنٌ

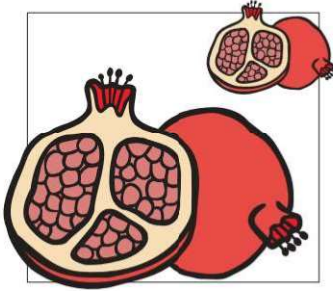

عَسَلٌ



زَيْتُونٌ

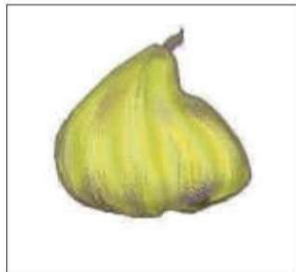

رُمَّانٌ

Exercise 4:

Do you know what letter is missing from the beginning of these words?

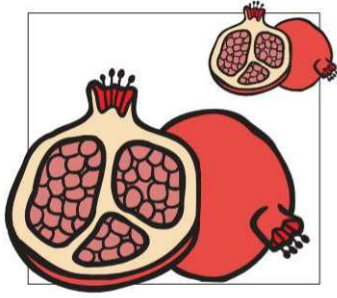

...مَانٌ



...يْتُونُ



...سَلٌ



...يِنٌ

9

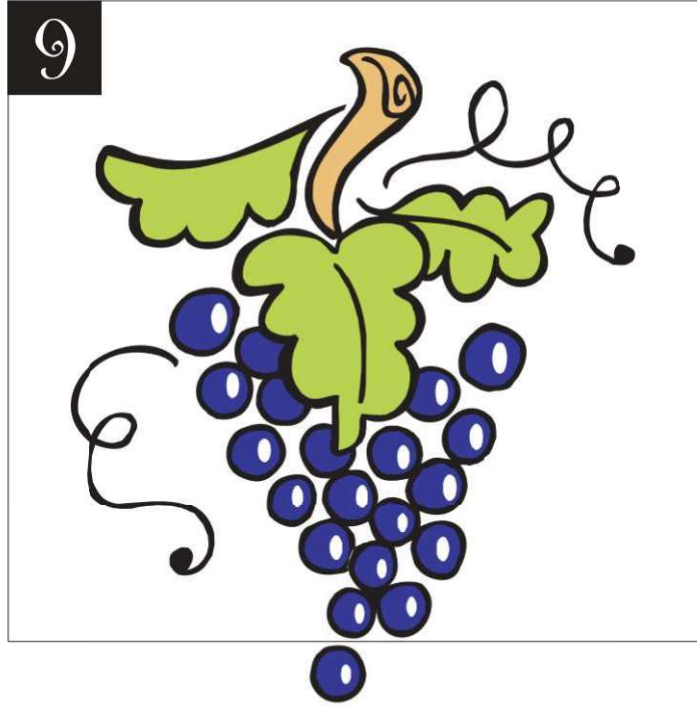

عِنَبٌ

Grapes

10



حَبَّ

Corn

١١

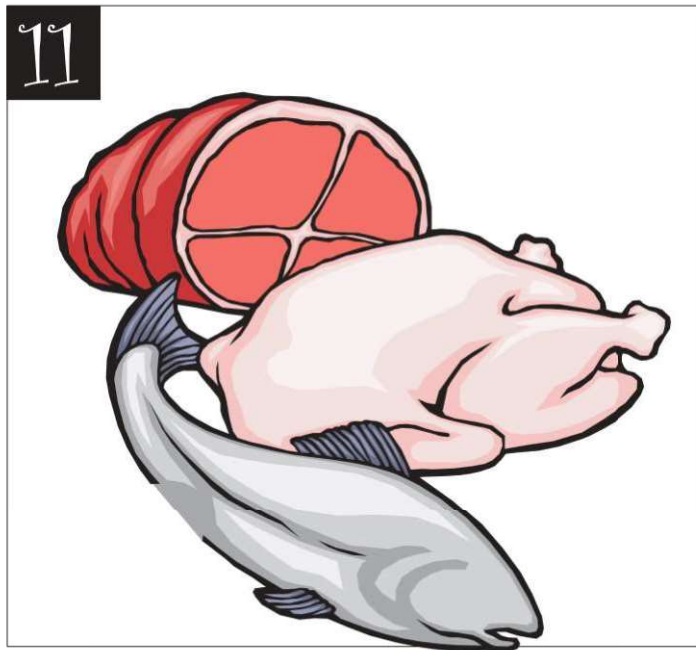

لَحْمٌ

Meat

12



فَاكِهَةٌ

Fruits

Exercise 5:

Draw a line to join the picture with the Arabic word.



عَنْبٌ

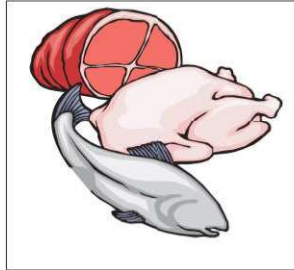

فَاكِهَةٌ



فِ

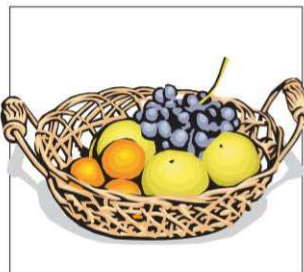

فِي

Exercise 6:

Do you know what letter is missing from the beginning of these words?

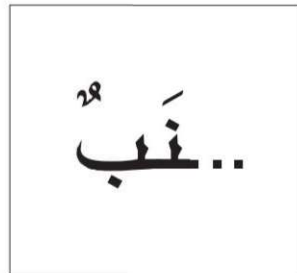
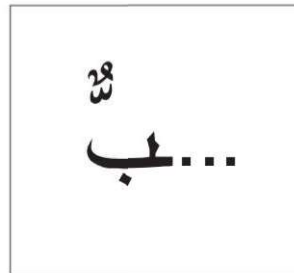
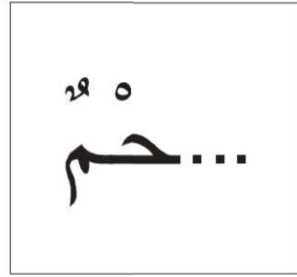
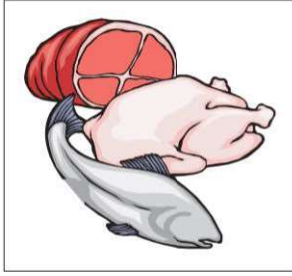

# The book of animals

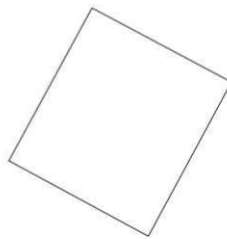
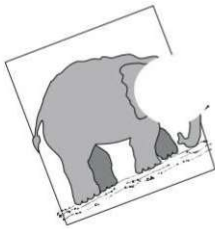
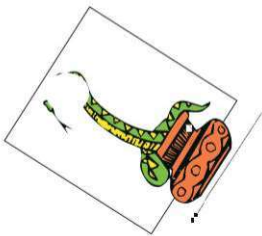

# Helping your child



The activities in this book should be enjoyed by your child and yourself.

Try to find a quiet place to work.



Always give your child lots of encouragement and praise.





جَمَلٌ

Camel

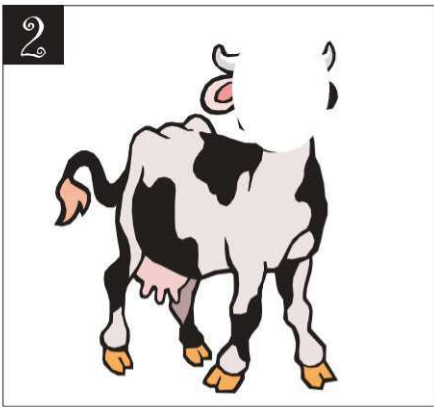

بَقْرَةٌ

Cow



عِجْلٌ

Calf (of a cow)

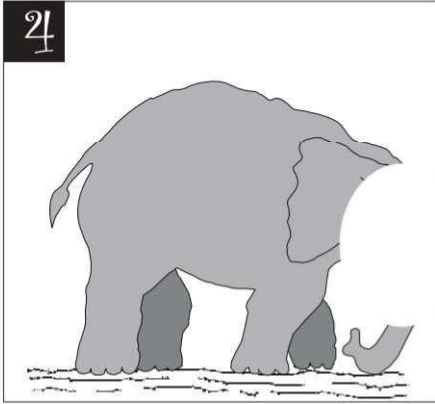

فَيْلٌ

Elephant

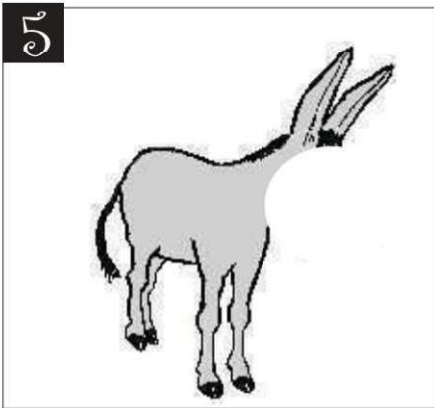

حِمَارٌ

Donkey

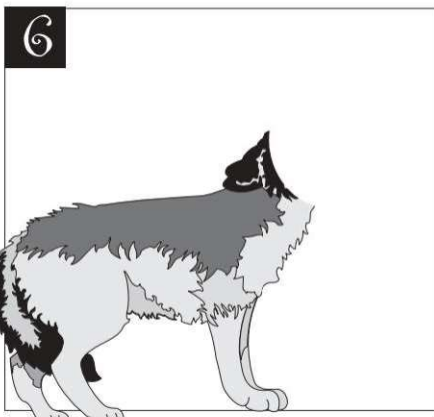

ذِئْبٌ

Wolf

Exercise 1:

Draw a line to join the picture with the Arabic word.

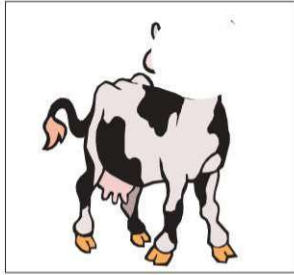

فَيْلٌ

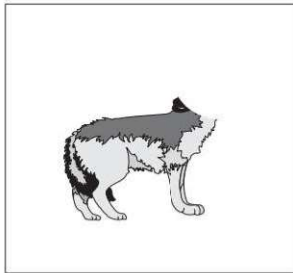

جَمَلٌ

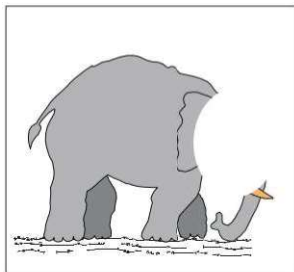

بَقْرَةٌ

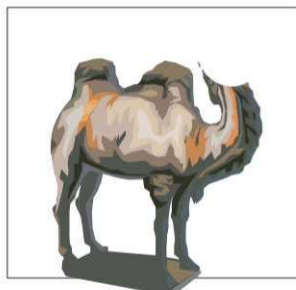

زَيْبٌ

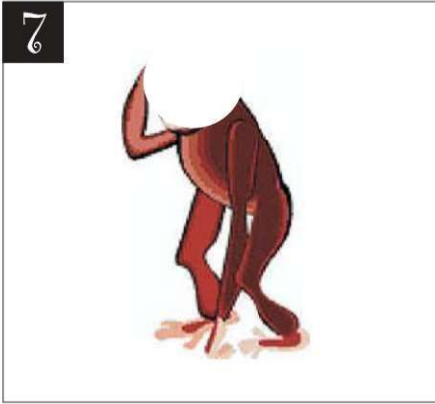

قِرْدٌ

Monkey

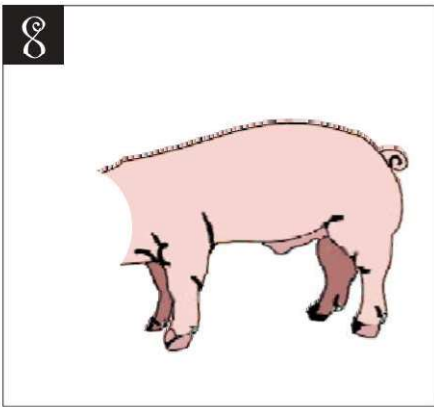

خِنْزِيرٌ

Pig

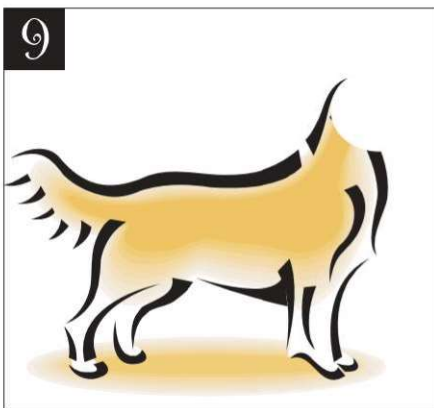

كَلْبٌ

Dog

10

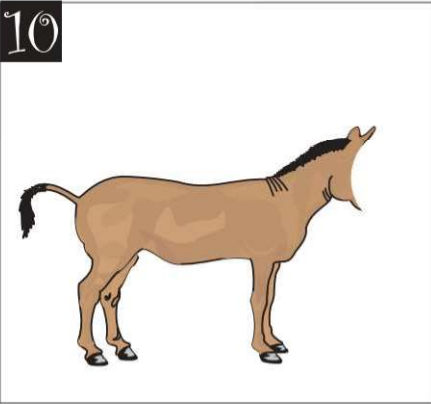

بَعْلٌ

Mule

A Mule is a cross breed between a horse and a donkey.

11

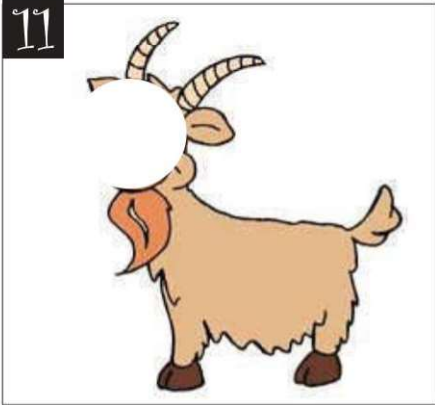

مَعَزٌ

Goat

12



ضَفْدَعٌ

Frog

Exercise 2:

Draw a line to join the picture with the Arabic word.



كَلْبٌ

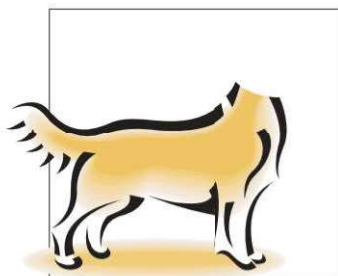

قِرْدٌ

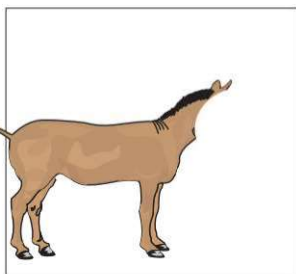

ضَفْدَعٌ

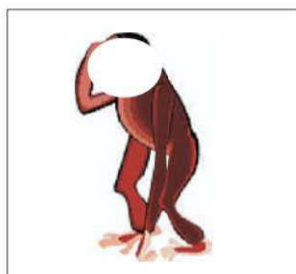

بَعْلٌ

13

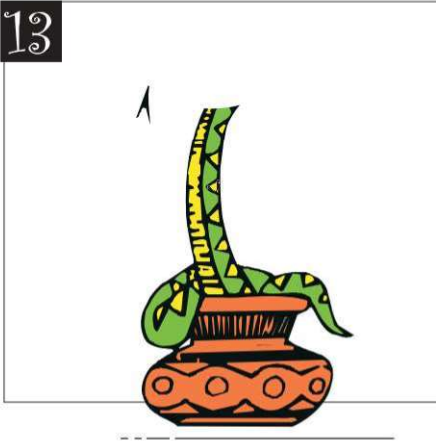

تُغَبَانٌ

Snake

14



غُرَابٌ

Crow

15



حُوتٌ

Fish

16

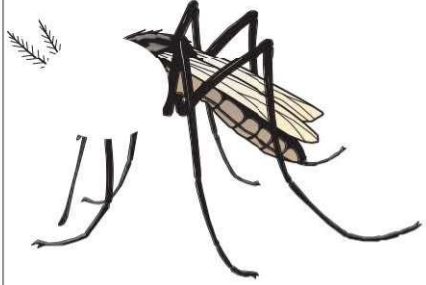

بَعُوضَةٌ

Mosquito

17

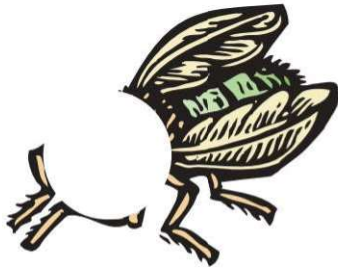

ذَبَابٌ

Fly

18



عَنْكَبُوتٌ

Spider

Exercise 3:

Draw a line to join the picture with the Arabic word.



تُعْبَانٌ



غُرَابٌ

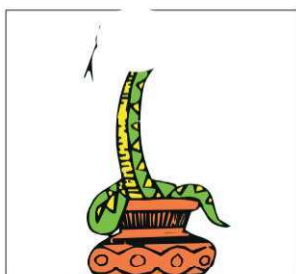

ذُبَابٌ



عَنْكَبُوتٌ

19



نَحْلَةٌ

Bee

20



فَرَّاشَةٌ

Butterfly

21



نَمْلَةٌ

Ant

Exercise 4

Draw a line to join the picture with the Arabic word.



نَمْلَةٌ



نَحْلَةٌ

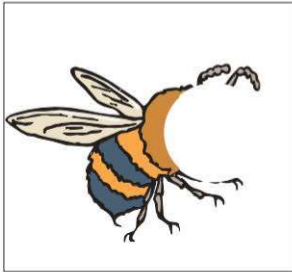

حُوتٌ



فَرَأَشَةٌ

## Collective Nouns



إِبِلٌ

A flock of  
camels

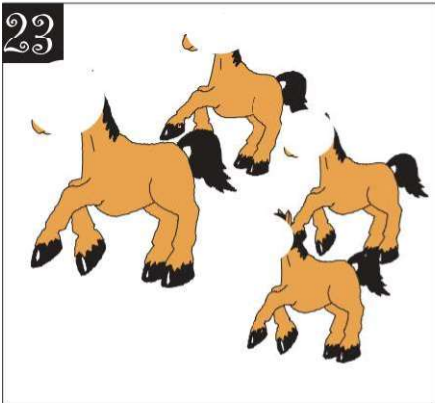

خَيْلٌ

A herd of  
horses

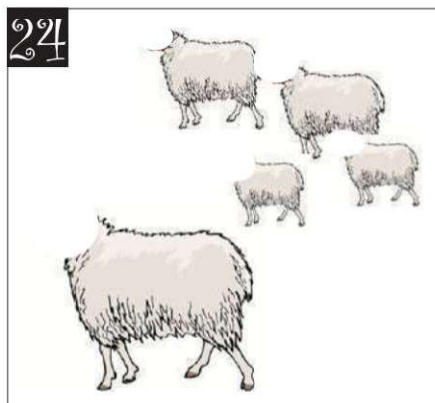

غَنَمٌ

A flock of  
sheep

# Shapes

## الأشكال

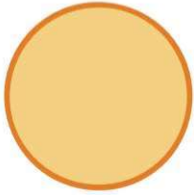

دَائِرَةٌ

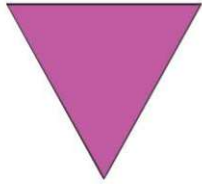

مُثَلَّثٌ



مُرَبَّعٌ



مُسْتَطِيلٌ



# Shapes الأشكال

## Teacher Notes

The four shapes that the children are going to learn about are:

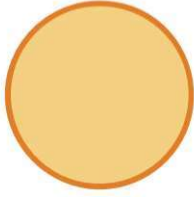

دَائِرَةٌ

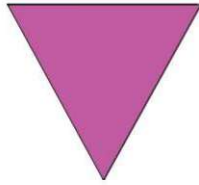

مُثَلَّثٌ

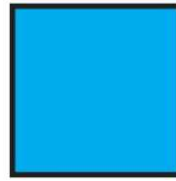

مُرَبَّعٌ

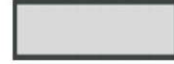

مُسْتَطِيلٌ

These shapes can be folded in half, and one half exactly covers the other half.

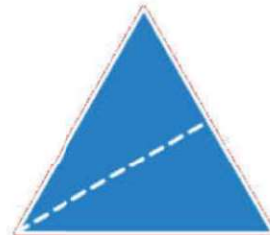
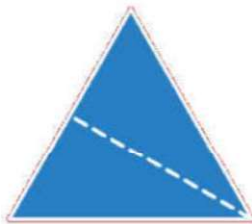
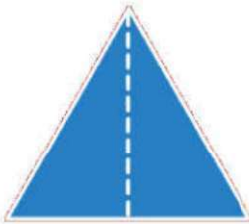

# ACTIVITY 1

The children should draw and colour the different shapes.



Shapes

# الأشكال

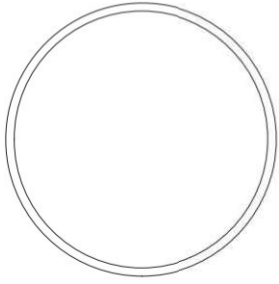

دَائِرَةٌ

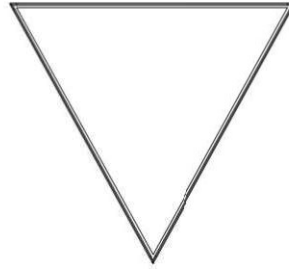

مُثَلَّثٌ

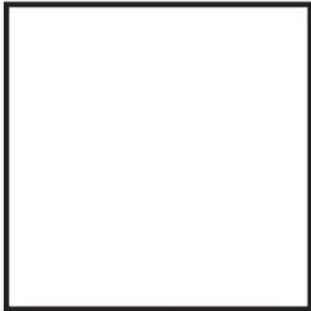

مُرَبَّعٌ



مُسْتَطِيلٌ

Which shape matches the balls?

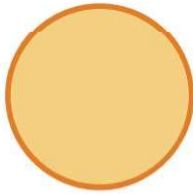

دَائِرَةٌ

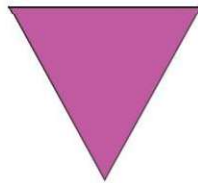

مُثَلَّثٌ

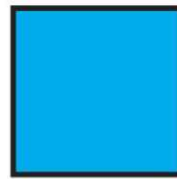

مُرَبَّعٌ



مُسْتَطِيلٌ

Which shape matches the sail  
on the boat?

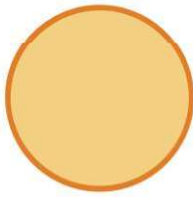
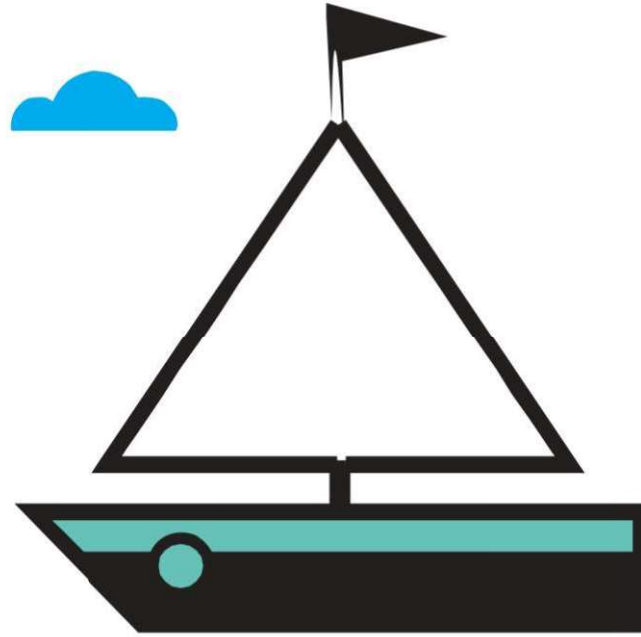

دَائِرَةٌ

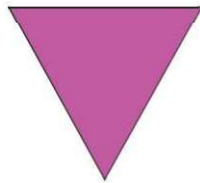

مُثَلَّثٌ

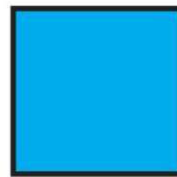

مُرَبَّعٌ



مُسْتَطِيلٌ

Which shape matches the picture frame?

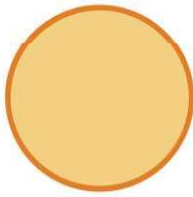
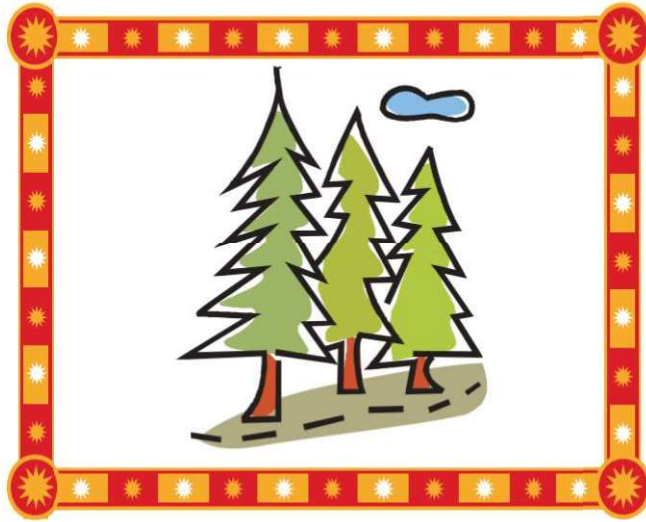
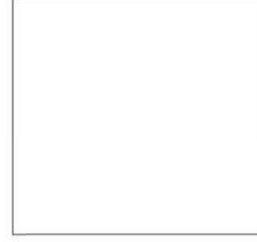

دَائِرَةٌ

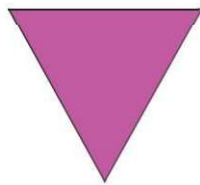

مُثَلَّثٌ

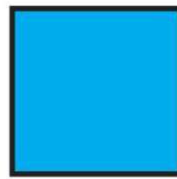

مُرَبَّعٌ



مُسْتَطِيلٌ

Which shape matches the fish tank?

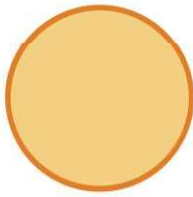
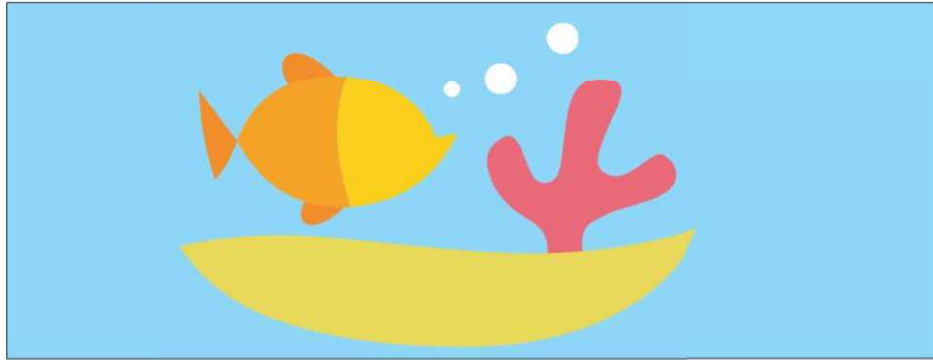

دَائِرَةٌ

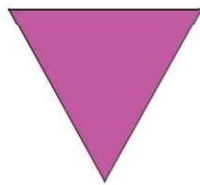

مُثَلَّثٌ

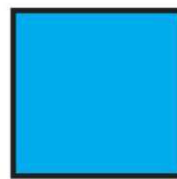

مُرَبَّعٌ

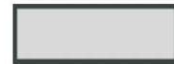

مُسْتَطِيلٌ

# Vocabulary of Saheehul-Bukhaaree



My Colouring Book

# Helping your child

## Tips



The activities in this book should be enjoyed by your child.

Try to find a quiet place to work.



Always give your child lots of encouragement and praise.



# 1) Arrow

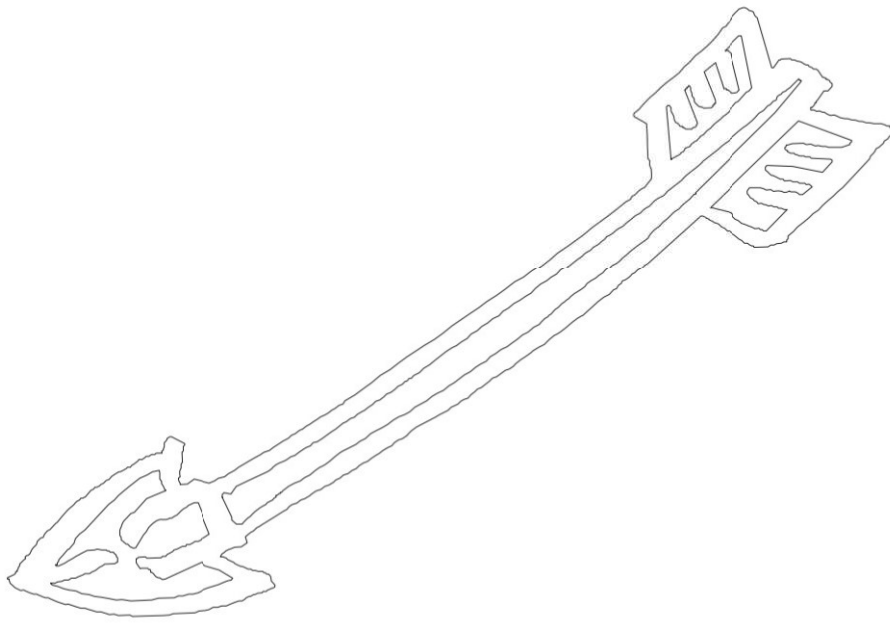

۲۰ -  
سه

## 2) Necklace

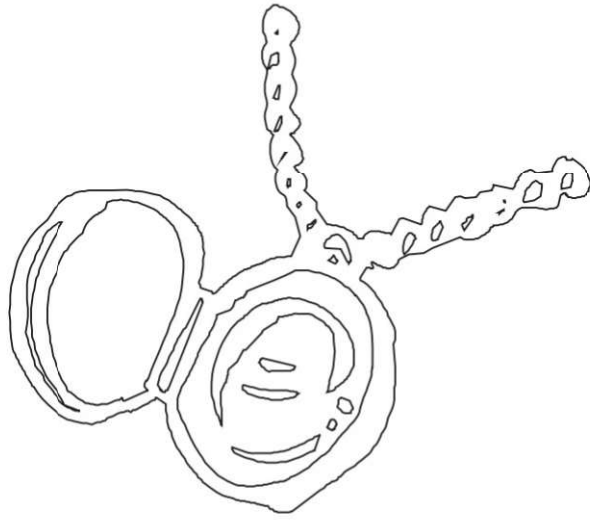

عَقْدُ

/

### 3) Bowl

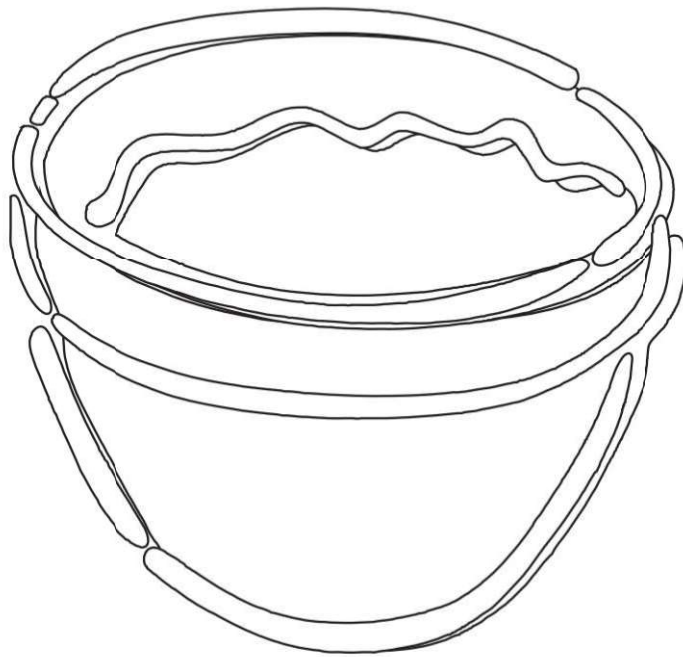

قَدَحٌ

## 4) Bed

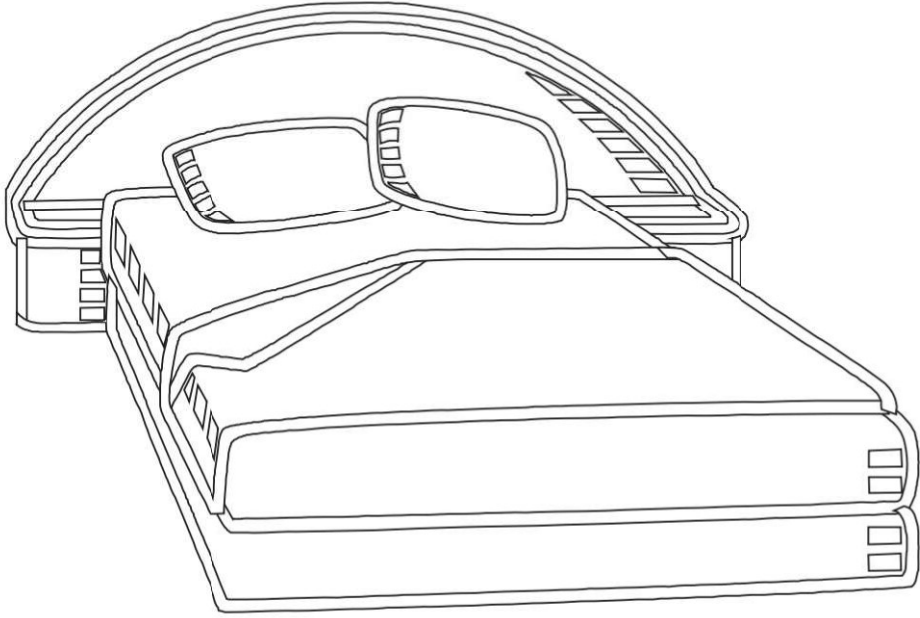

فِرَاشٌ

Exercise 1:

Draw a line to join the picture with the Arabic word.

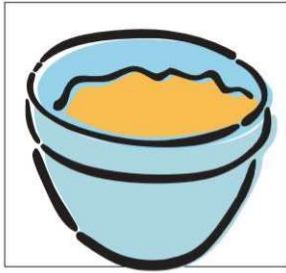

قَدَحٌ

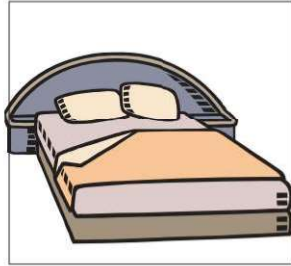

سَهْمٌ

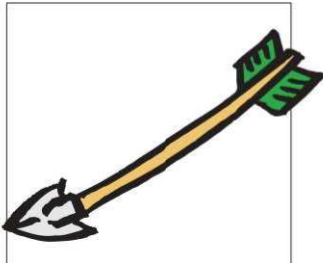

عَقْدٌ

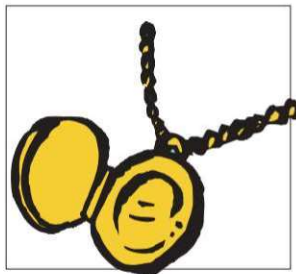

فِرَاشٌ

## 5) Honey

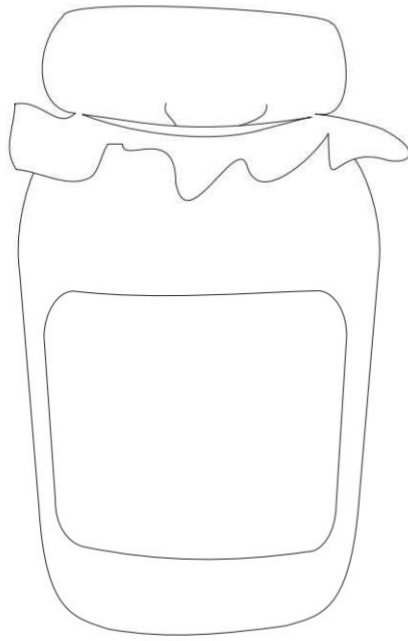

عَسَلٌ

## 6) Drink

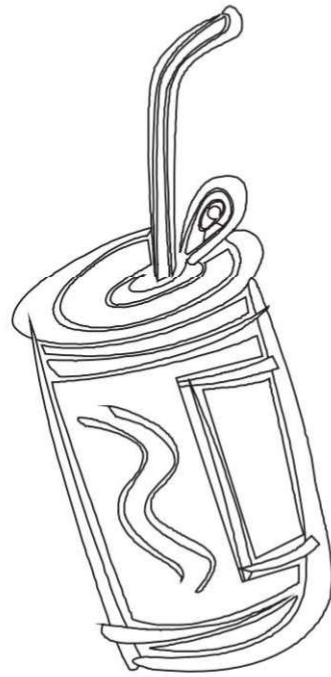

شَرَابٌ

## 7) Grapes



عَنْبُ

## 8) House



دَارٌ

Exercise 2:

Draw a line to join the picture with the Arabic word.



شَرَابٌ



عَسَلٌ



دَارٌ



عِنَبٌ

## 9) Curtain

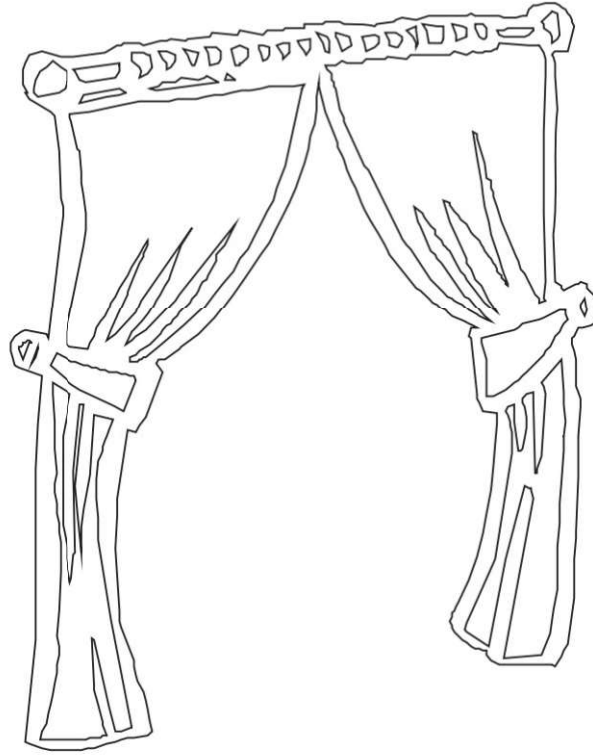

سٲر

## 10) Shoe

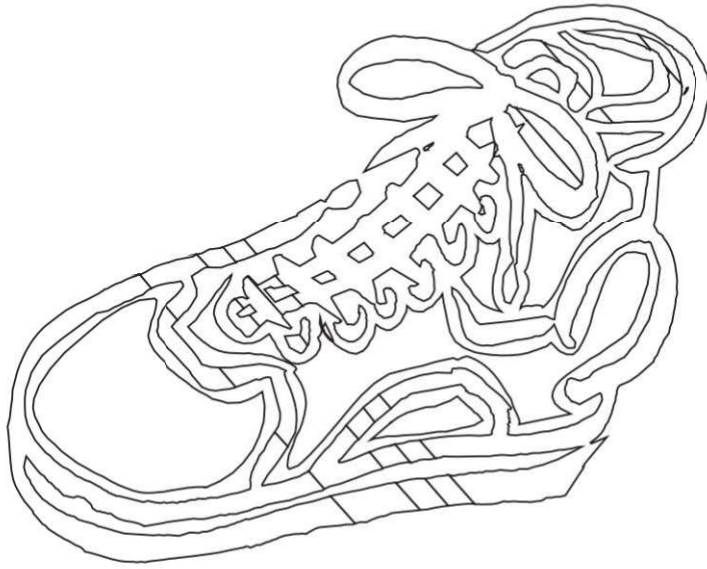

أَبْعَل

# 11) Boat

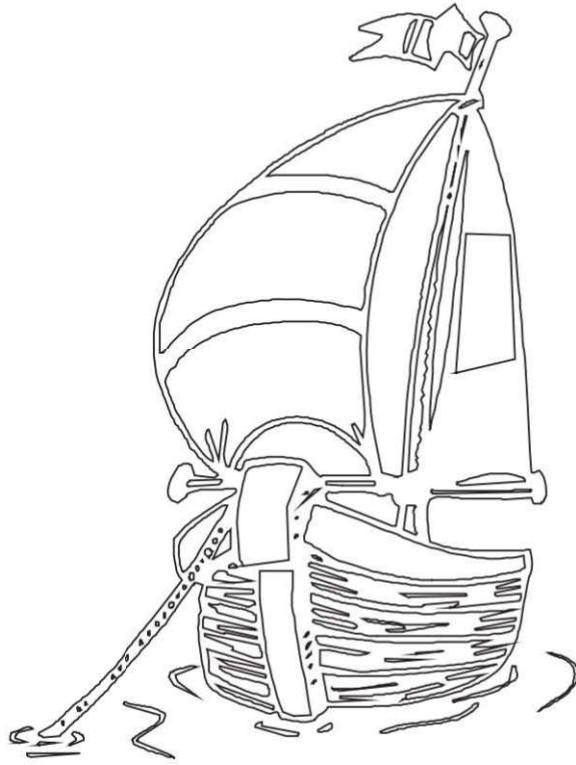

سَفِينَةٌ

## 12) Roof

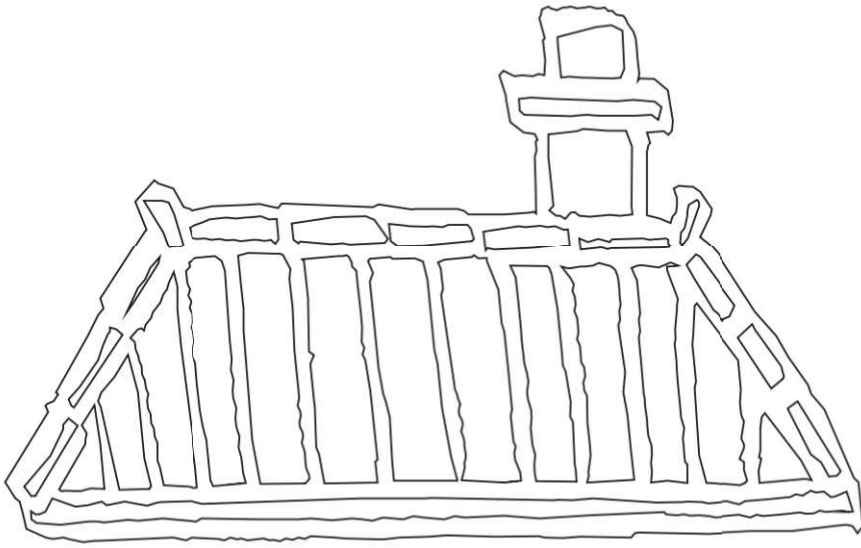

سَقْفٌ

Exercise 3:

Draw a line to join the picture with the Arabic word.

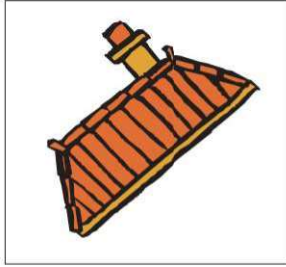

سَـتْرٌ



نَعْلٌ



سَقْفٌ



سَفِينَةٌ

## 13) Ring

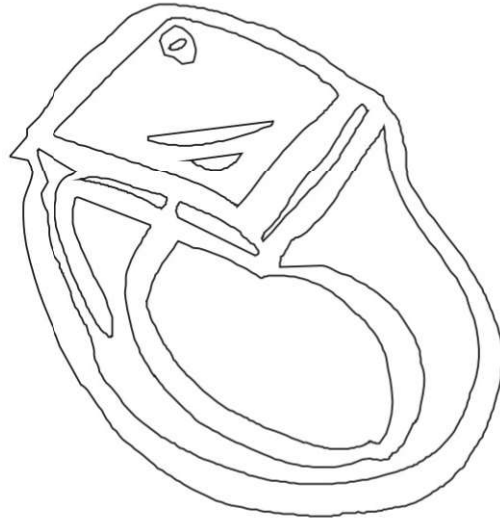

خَاتَمٌ

## 14) Treasure



كَنْزٌ

## 15) Soup



مَرَقٌ

# 16) Town

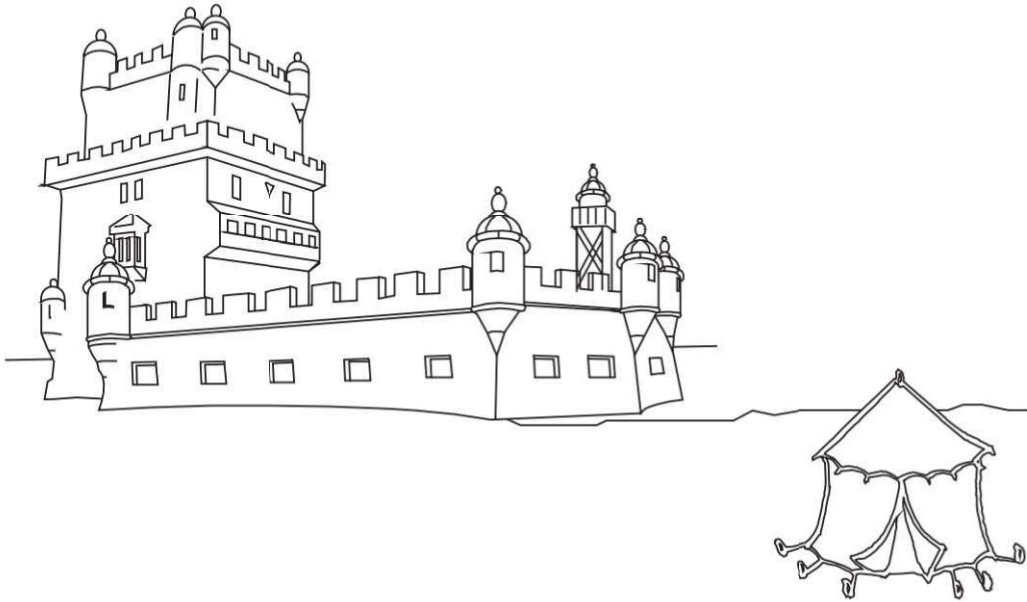

بَلَدَةٌ

### Exercise 4

Draw a line to join the picture with the Arabic word.

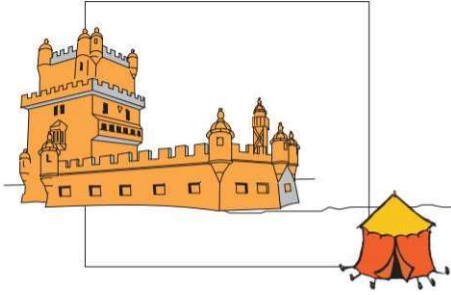

مَرَقٌ



خَاتَمٌ



بَلَدَةٌ



كَنْزٌ

# 1) Tent

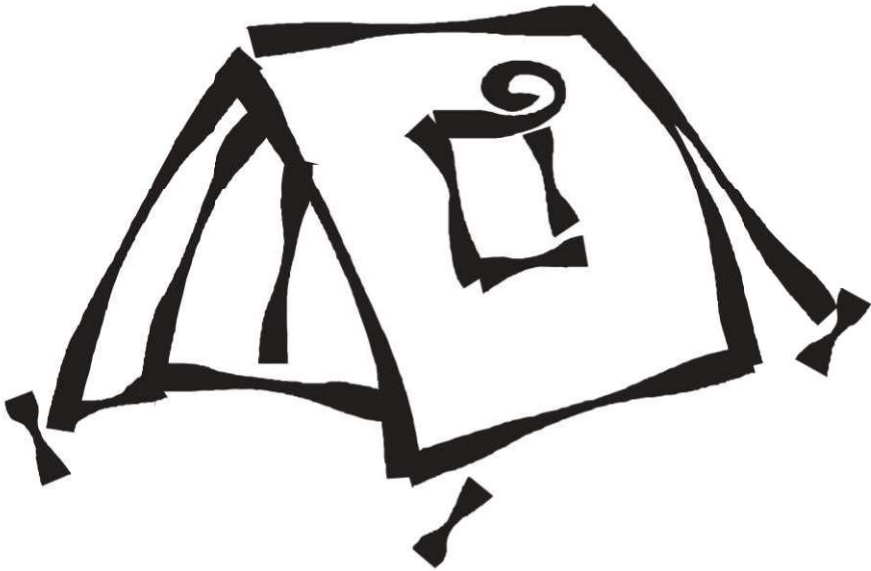

حَيْمَةٌ

## 2) Egg

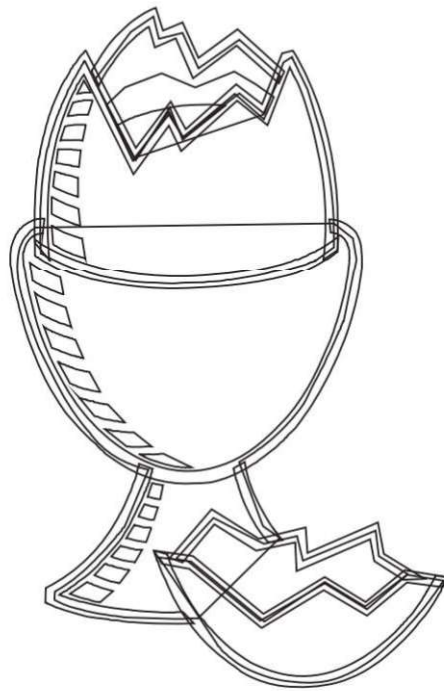

يَيْضَةٌ

### 3) Bandage

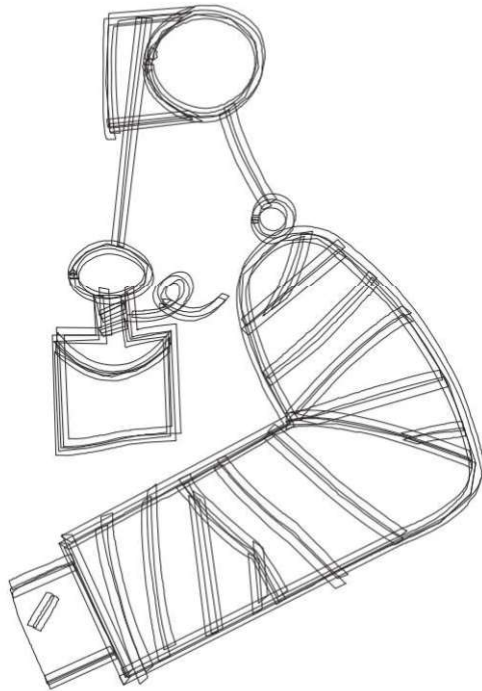

عَصَابٌ

## 4) Scrolls

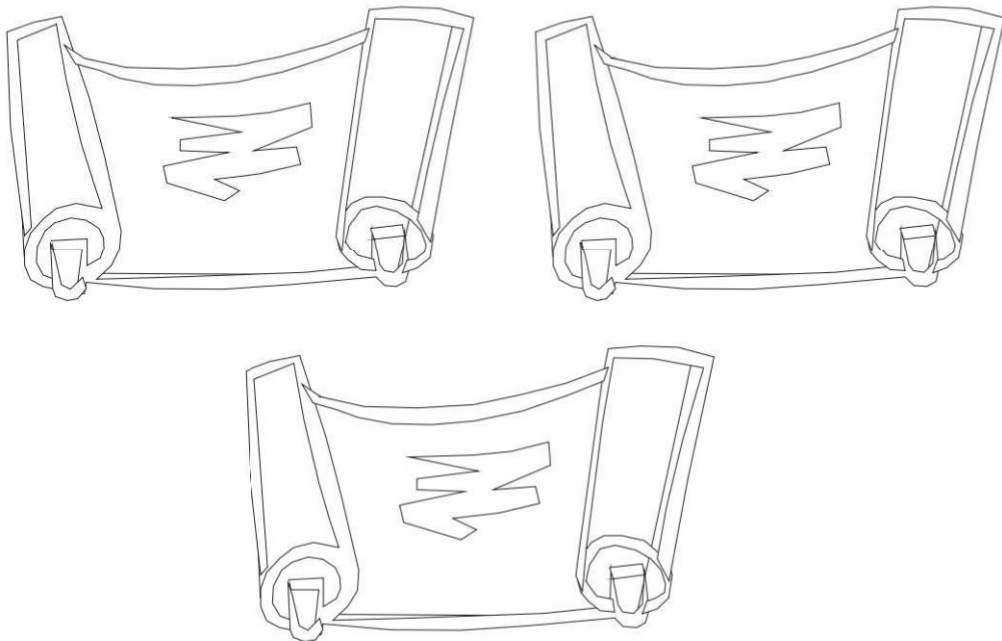

صُحُفٌ

Exercise 1:

Draw a line to join the picture with the Arabic word.

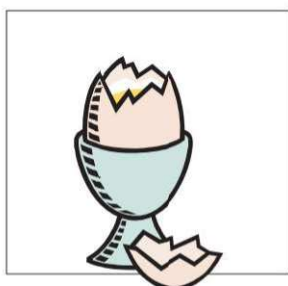

صُحُفٌ



عَصَابٌ

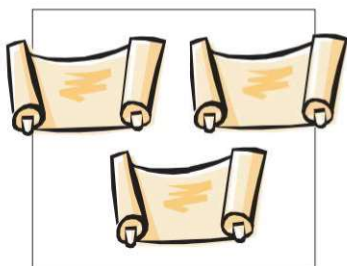

خَيْمَةٌ



بَيْضَةٌ

## 5) Turban

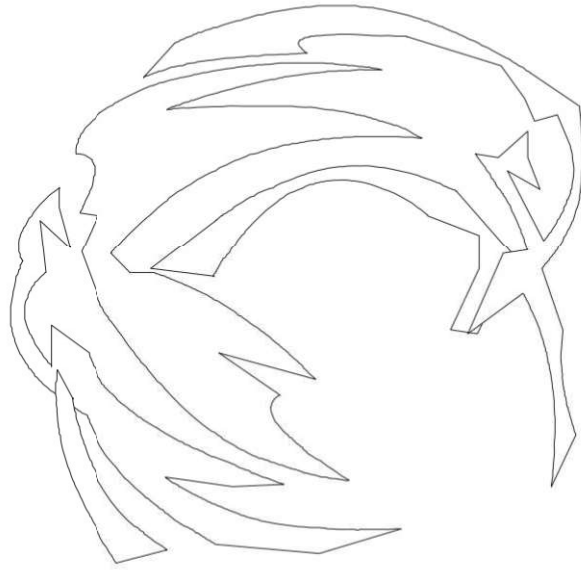

عِمَامَةٌ

## 6) Pearls



لؤلؤ

## 7) Wind



رِيح

## 8) Tree

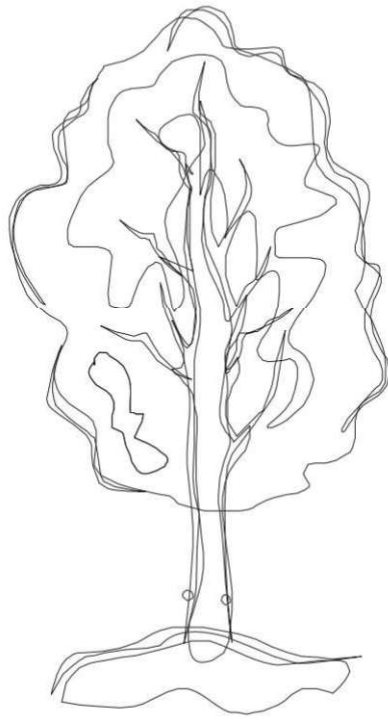

شجره

Exercise 2:

Draw a line to join the picture with the Arabic word.



لَوْلُو



رِيح

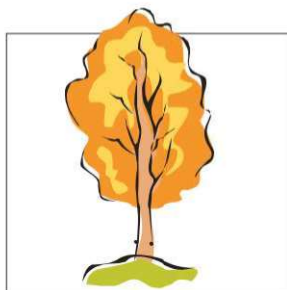

شَجَرَةٌ



عِمَامَةٌ

## 9) Well

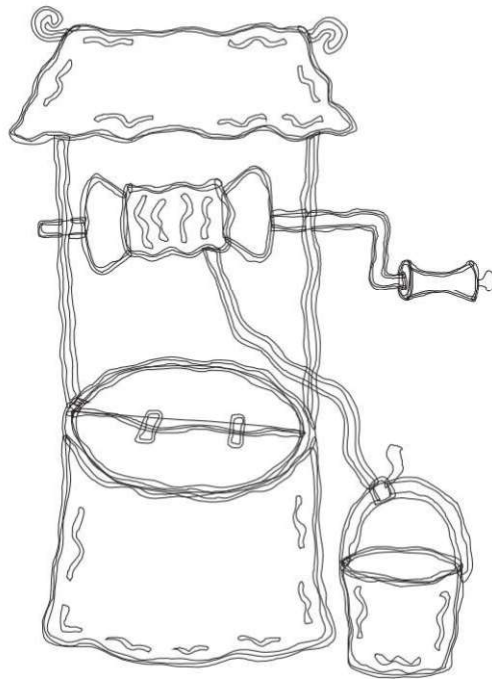

أَقْلِبْ

# 10) Bucket

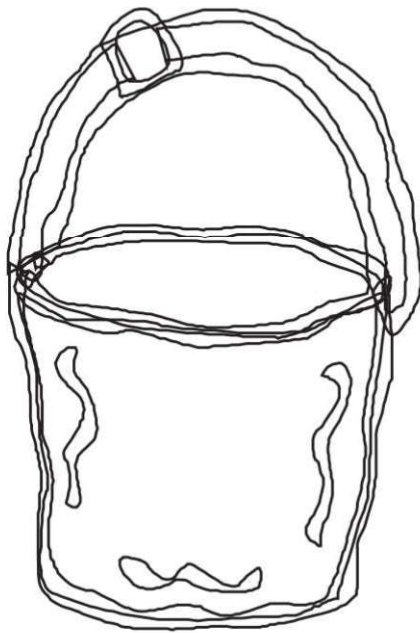

دَبُو

# 11) Weapons

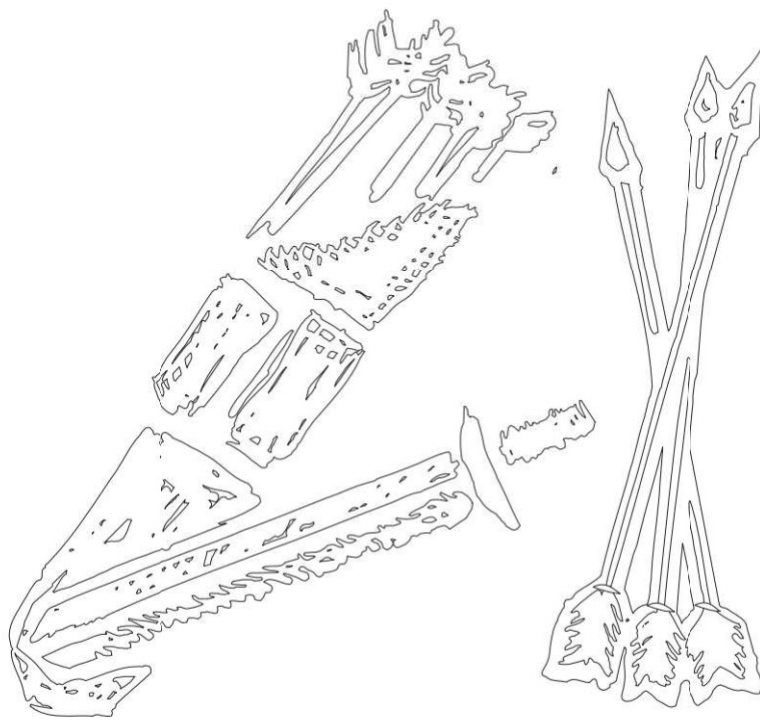

سِلَاحٌ

## 12) Milk

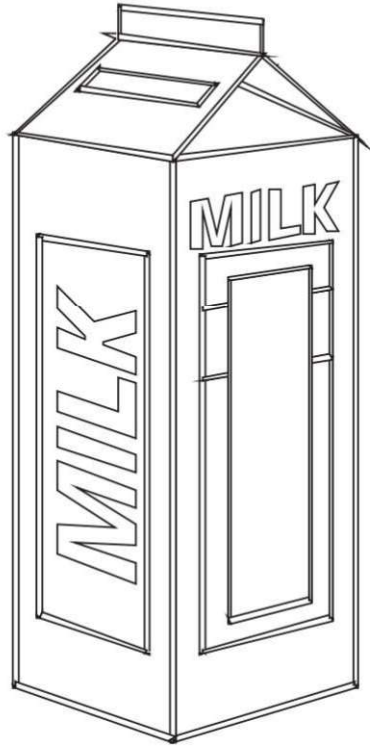

أَبْنِ

Exercise 3:

Draw a line to join the picture with the Arabic word.



لَبَنٌ



دَلْوٌ



قَلِيبٌ



سِلَاحٌ

# 13) Stick



عَوْد

# 14) Fingernail

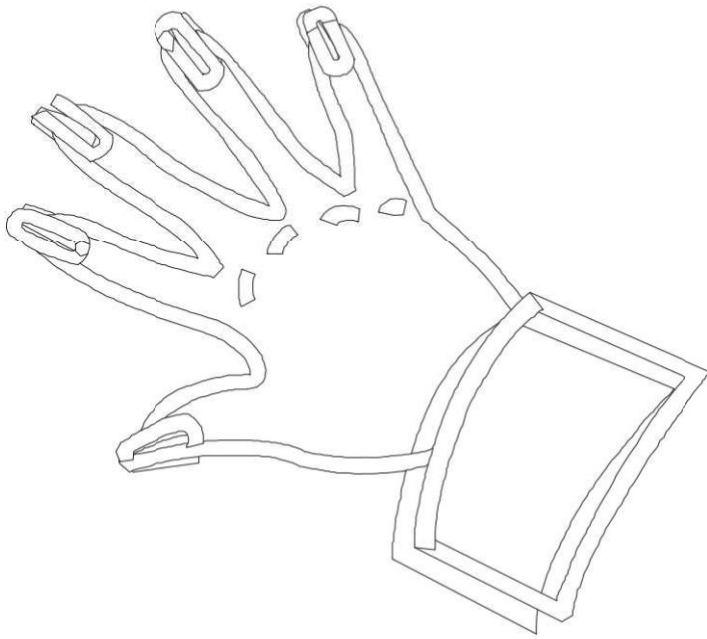

ظفر

# 15) Dust



غُبَارٌ

## 16) Straw

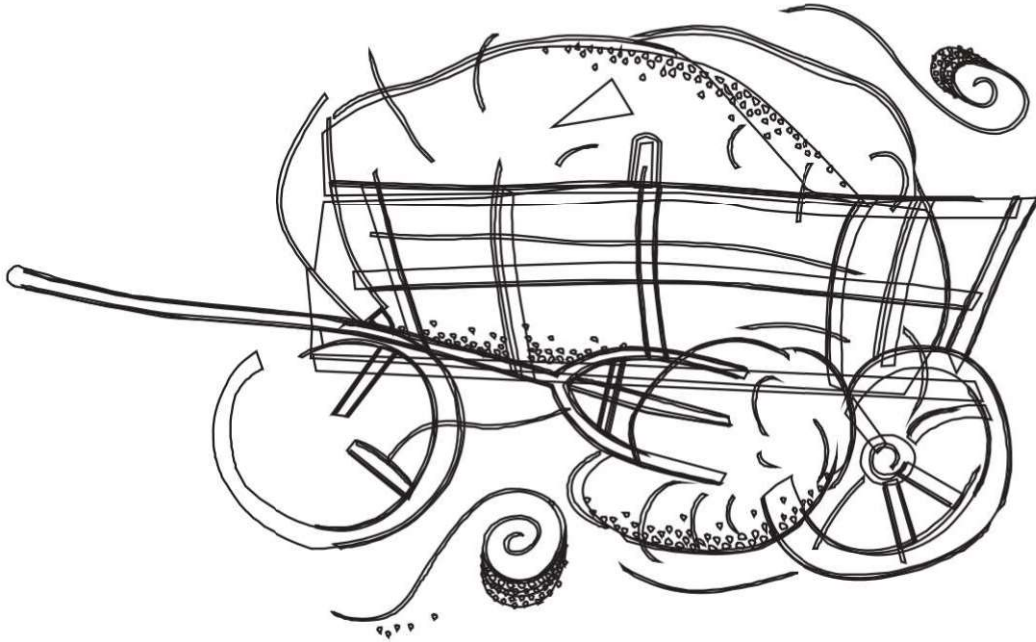

سُوپِن

### Exercise 4

Draw a line to join the picture with the Arabic word.

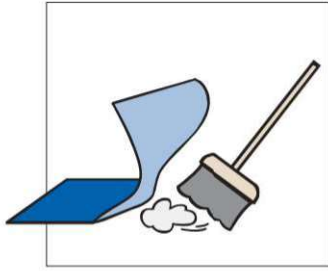

عود

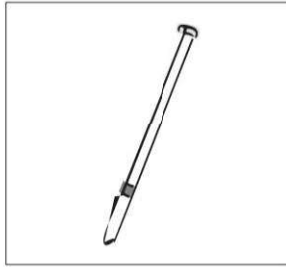

ظفر

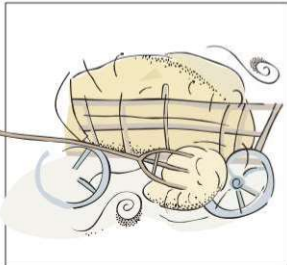

غبار



يَبْنِ

# 1) Basket



مِثْلُ

## 2) Rock

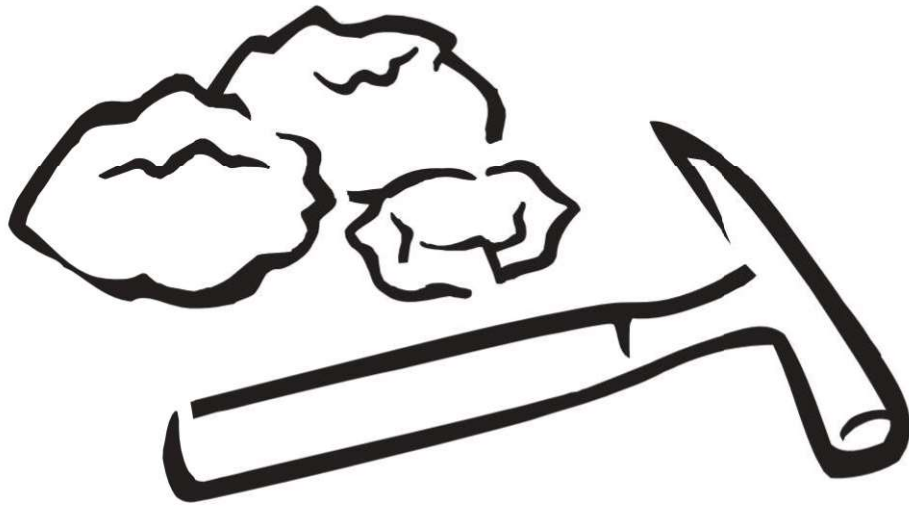

صَخْرَةٌ

### 3) Knife

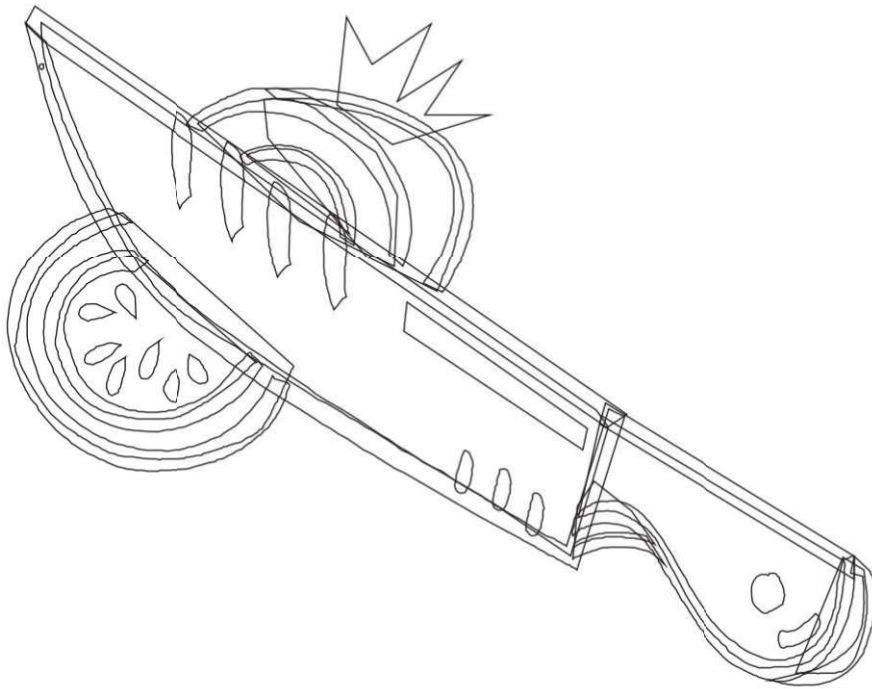

سکین

## 4) Clouds



غَمَامٌ

Exercise 1:

Draw a line to join the picture with the Arabic word.

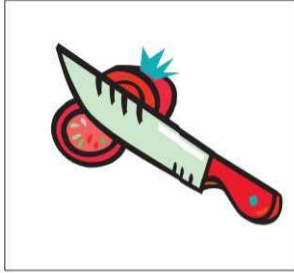

مَكْتَلٌ

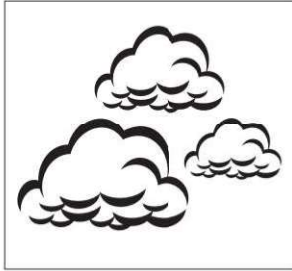

صَخْرَةٌ



سَكِينٌ



غَمَامٌ

## 5) Beak (of a bird)

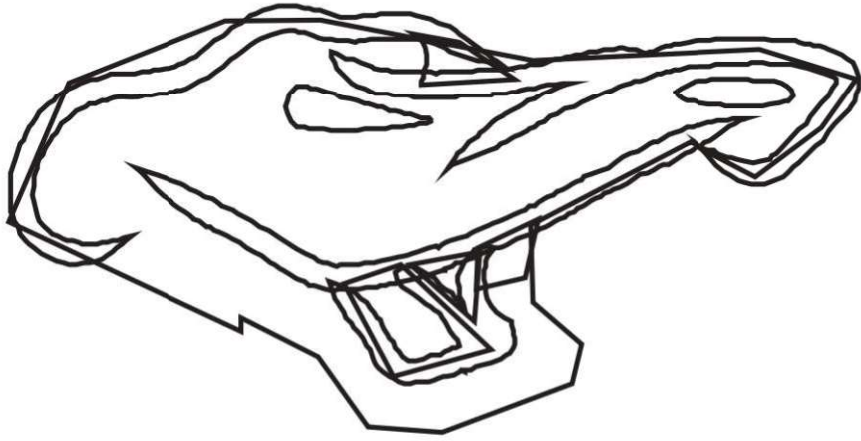

مِنْقَارٌ

## 6) Thumb

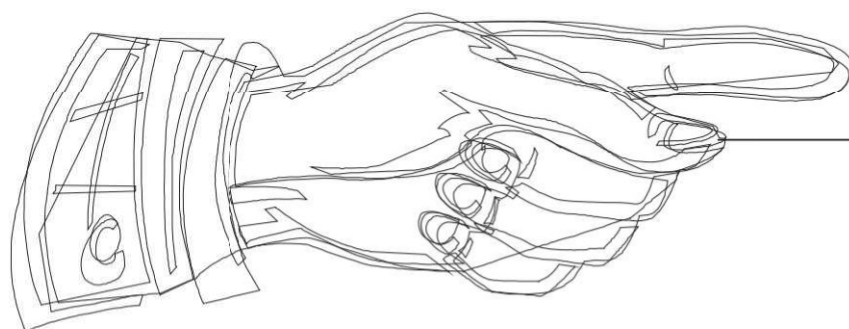

إِبْهَامٌ

## 7) Wall

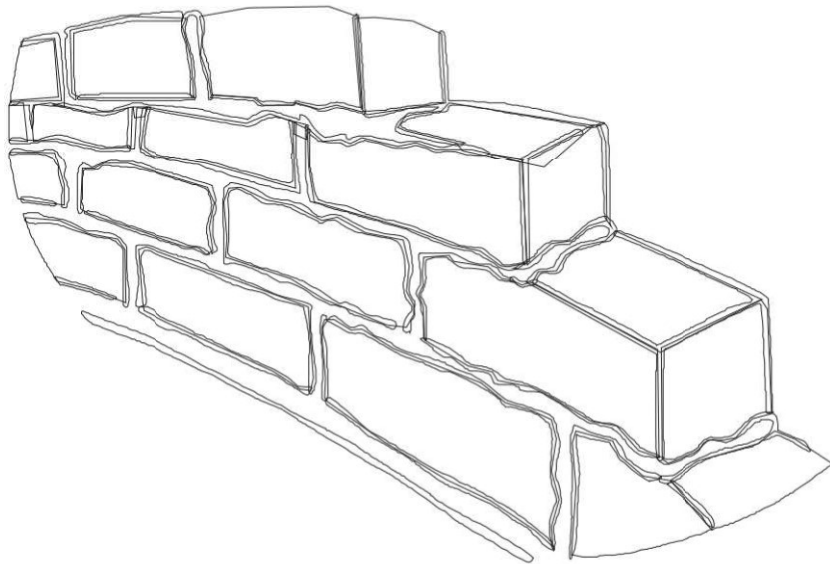

جِدَارٌ

## 8) Moon

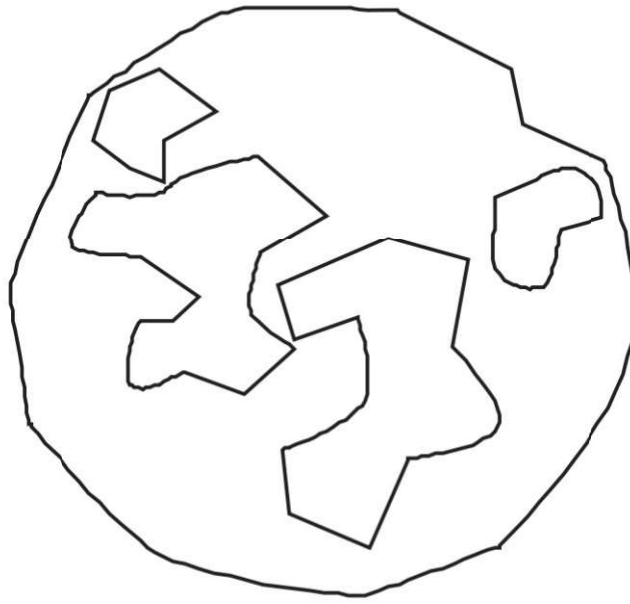

القمر

Exercise 2:

Draw a line to join the picture with the Arabic word.

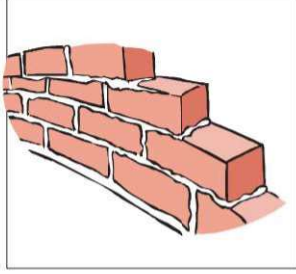

مِنْقَارٌ

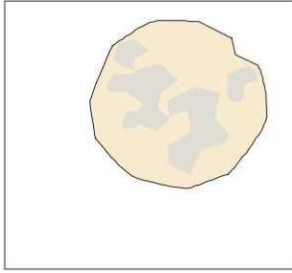

جِدَارٌ



قَمَرٌ



إِبْهَامٌ

## 9) Smoke



دُخَانٌ

## 10) Corner

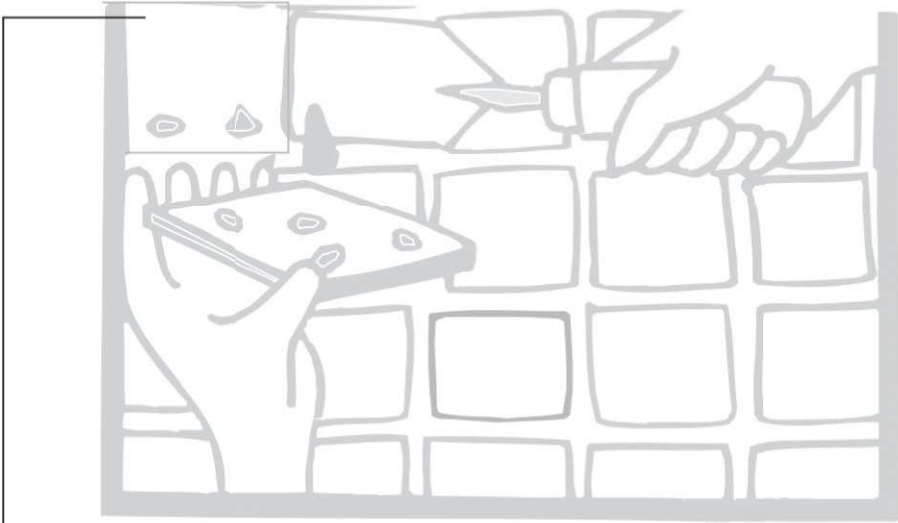

زَاوِيَةٌ

# 11) Cucumber

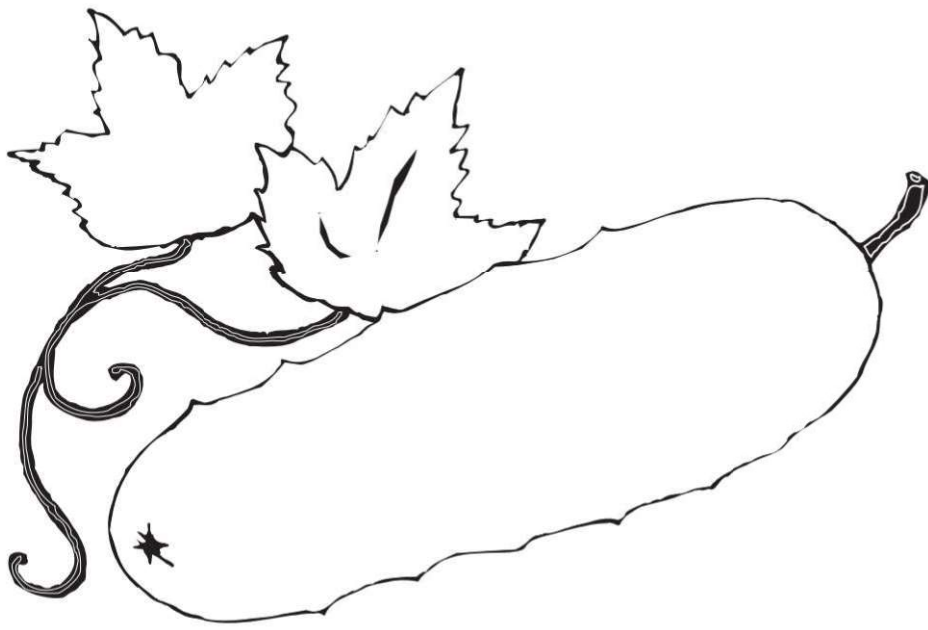

ب  
ق  
ف  
ق  
ع  
ا

## 12) Dates

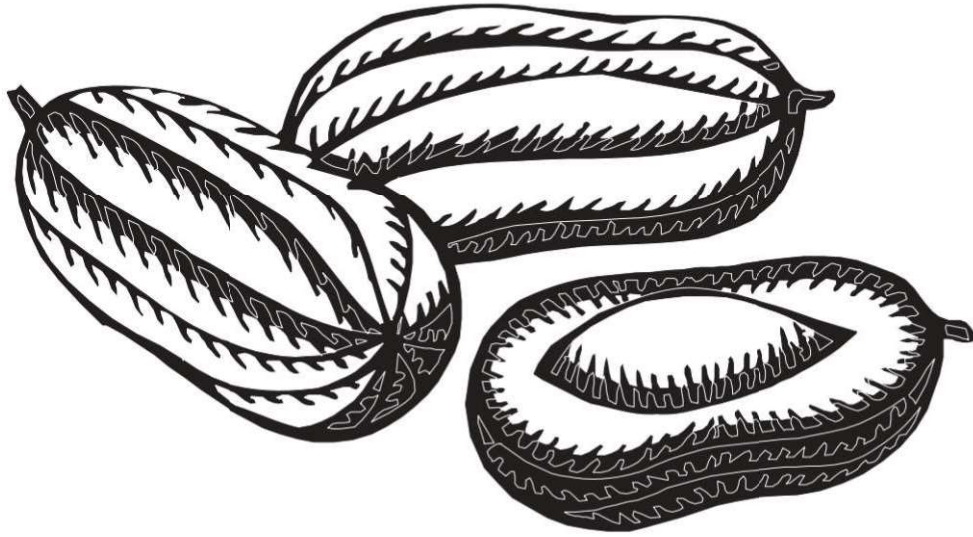

تَمْر

Exercise 3:

Draw a line to join the picture with the Arabic word.



قَتَاءٌ



زَاوِيَةٌ

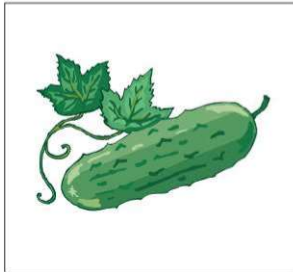

دُخَانٌ

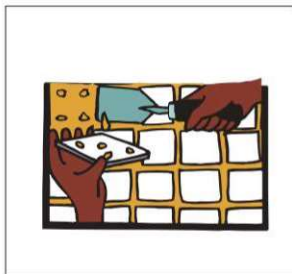

تَيْمَرٌ

# 13) Bread

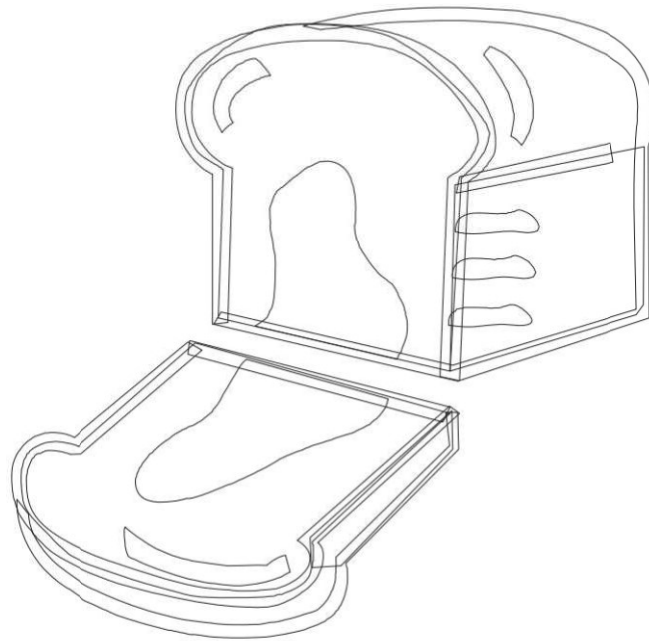

۲۰۶  
خبز

## 14) Big tray

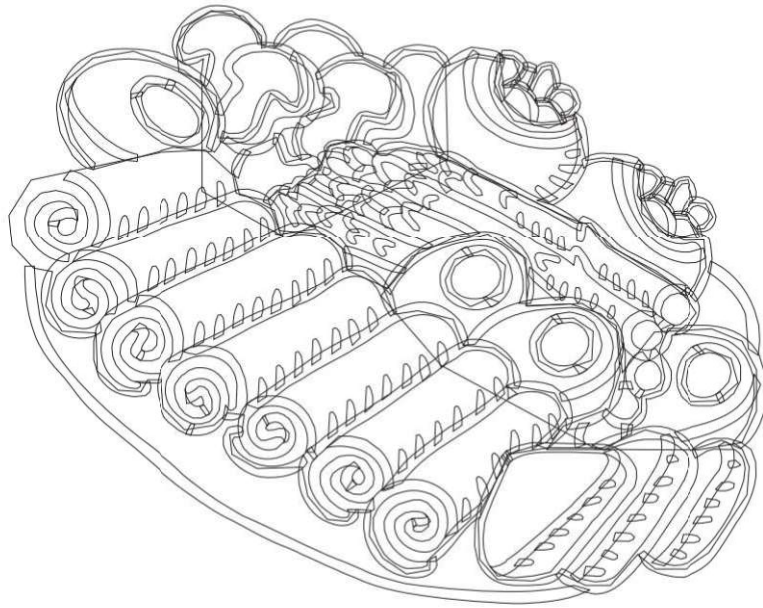

سُكْرَجَةٌ

## 15) Dining table

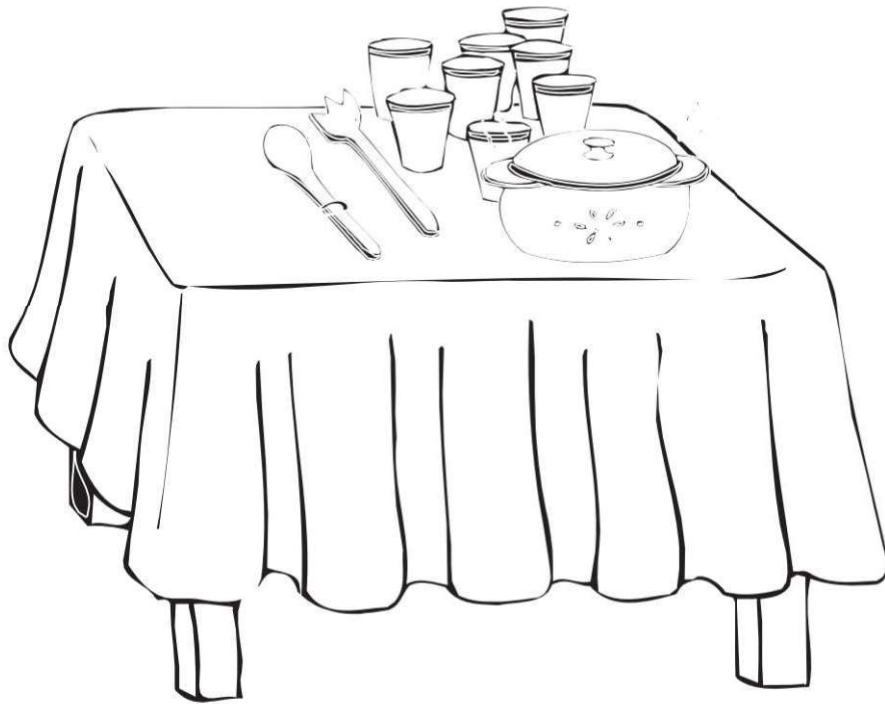

٢٤  
خَوَانِ

# 16) Waterskin

A bag serving as a container for liquids; it is made from the skin of an animal.

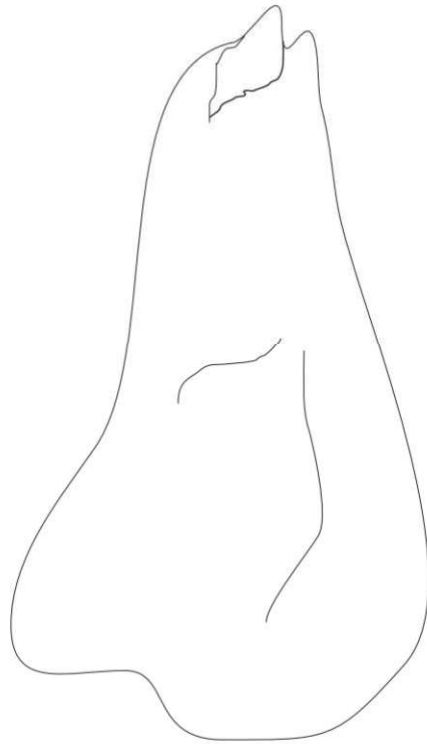

قِرْبَةٌ

### Exercise 4

Draw a line to join the picture with the Arabic word.

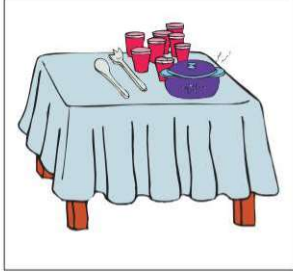

قَرَبَةٌ



خَوَانٌ

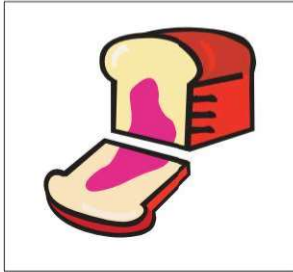

سُكَّرُجَةٌ



خَبِزٌ

---

## TEACHING INSTRUCTIONS

السَّلَامُ عَلَيْكُمْ وَرَحْمَةُ اللَّهِ وَبَرَكَاتُهُ

Praise be to Allaah, the Lord of the Worlds and Peace and Blessings of Allaah be upon Muhammed, the best of all creations, his family and companions and those who follow them in truth until the Day of Judgement.

Dear Teachers... whether you are teaching from your Home, School or Madrasa, we would like to share some insight into the teaching methods that should be adopted regarding this book.

The book is meant for students aged 6 years and above and for Grade 1 in Madrasa and as such the main purpose of the contents of this book is the build up of Arabic vocabulary skills and memorization of day-to-day terms used in the Arabic language.

Writing Arabic with joined letters will be introduced in this Grade, So the words and their meanings in the various lessons are to be memorized orally as well as made to write to improve the handwriting skills.

Simultaneously, vocabulary build-up can be made interesting by introducing the colouring book from the beginning of the course, though keeping in mind that the purpose of colouring is to memorize the words on the pages with their meaning.

Regular Class Tests should be conducted to test the memorisation of the Arabic words with their meanings in these lessons.

By the End of the Year, Teachers should make sure that the Students have learned the Arabic words with their right articulation (makhraj) and the meanings of all the words in the book.

JazakAllahu Khairan

# Arabic Reader

---